



Series 500

# Side Mount

Threaded or Flange, Pressure to 400 psig (28 bar), Hermetically Sealed Switches, Temperature to 425°F (218°C)



Series 500 F Flanged cast iron type (ANSI 2 1/2", 125 lb cast iron flange as standard). Steel body furnished (with ANSI 2 1/2" 150 lb forged steel flange) for direct mounting.

Large flanges available on special order.

Single Stage<sup>(1)</sup> available with threaded or flanged connection.

FLOAT ROD LENGTH	FLOAT INSERTION		MINIMUM SPECIFIC GRAVITY		ADJUSTABLE "D" DIFFERENTIAL	MAX. "A" ABOVE C/L	MAX. "B" BELOW C/L
	2 1/2" (64mm) FLOAT	2 1/2" x 4" (64 x 102mm) FLOAT	2 1/2" (64mm) FLOAT	2 1/2" x 4" (64 x 102mm) FLOAT			
6" (153 mm)	6 1/2" (165 mm)	8" (203 mm)	.80	.55	<sup>(1)</sup> MAX. 3" (76 mm) MIN. 1/2" (13 mm)	1 7/8" (48 mm) 1 3/4" (44 mm)	3 3/8" (86 mm) 2 3/4" (70 mm)
12" (305 mm)	12 1/2" (318 mm)	14" (356 mm)	.90	.60	<sup>(1)</sup> MAX. 5 1/4" (133 mm) MIN. 1" (25.4 mm)	3" (76 mm) 2 7/8" (73 mm)	6 3/8" (162 mm) 5 1/4" (133 mm)
18" (457 mm)	18 1/2" (470 mm)	21" (533 mm)	1.0	.65	<sup>(1)</sup> MAX. 7 1/2" (191 mm) MIN. 1 1/2" (38 mm)	4 1/4" (108 mm) 4" (102 mm)	9 1/2" (241 mm) 7 3/4" (197 mm)
24" (610 mm)	24 1/2" (622 mm)	26" (660 mm)	1.1	.70	<sup>(1)</sup> MAX. 10" (254 mm) MIN. 2" (51 mm)	5 1/2" (140 mm) 5 1/8" (130 mm)	12 1/2" (318 mm) 10 1/4" (260 mm)

<sup>(1)</sup> If control is nozzle mounted, maximum differential will be limited by nozzle length.

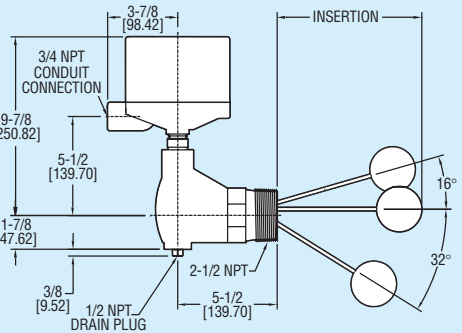

Two Stage (2 1/2" x 4" Float Only)<sup>(2)</sup> available with threaded or flanged connection.

FLOAT ROD LENGTH	INSERTION 2-1/2" x 4" (64 x 102mm) FLOAT	DIFFERENTIAL NOT ADJUSTABLE		BETWEEN STAGES NOT ADJUSTABLE			MINIMUM SPECIFIC GRAVITY
		BOTTOM STAGE (HIGH LEVEL) H	TOP STAGE (LOW LEVEL) L	BS	OVER C/L "O"	UNDER C/L "U"	
6" (153 mm)	8" (203 mm)	3/8" (10 mm)	3/8" (10 mm)	3 5/8" (93 mm)	1 1/4" (32 mm)	2 3/8" (60 mm)	.70
12" (305 mm)	14" (356 mm)	1/2" (13 mm)	7/8" (22 mm)	6 5/8" (168 mm)	2 1/8" (54 mm)	4 1/2" (114 mm)	.70
18" (457 mm)	20" (508 mm)	7/8" (22 mm)	1 1/4" (32 mm)	9 5/8" (244 mm)	2 7/8" (73 mm)	6 3/4" (171 mm)	.75
24" (610 mm)	26" (660 mm)	1 1/8" (29 mm)	1 1/2" (38 mm)	12 5/8" (321 mm)	3 5/8" (93 mm)	9" (229 mm)	.8

<sup>(2)</sup> Two stage operation requires 32° float rod movement below horizontal so flange must be bolted directly to tank as shown.

Level

**Adjustable deadband** combined with direct 2 1/2" threaded or 2 1/2" flange mount makes the reliable, heavy duty 500 Series ideal for liquid level control in large or small tanks. Chambers are available in cast iron, cast steel or cast 316 stainless steel to meet the most demanding application. Float rods are available from the standard 6" (152.4 mm) up to 24" (610 mm) long providing action down to a specific gravity of 0.55. 2 1/2" (64 mm) float is suitable for pressure of 400 psig (28 bar), 2 1/2" x 4" (64 x 102 mm) float is suitable for 200 psig (14 bar). Maximum operating temperature is 425°F (218°C). A variety of circuits can be ordered including SPST, SPDT or DPDT with hermetically sealed snap action or mercury contacts. Single pole, double throw electrically independent circuits are available as well as contact for high or low DC current applications. A full range of enclosures are available such as general purpose, (weather proof) (explosion proof) (explosion proof - vapor proof).

### Suggested Specification

Level switches shall be direct mount type with 2 1/2" NPT connection. Units shall have weather-proof enclosures. Contacts shall be (hermetically sealed) (mercury wetted) (snap action type). Switching mechanism shall be stainless steel with gravity return action. Stainless steel float shall actuate mechanism by magnetic linkage.

### SPECIFICATIONS

**Minimum Specific Gravity:** Dependent on float size and rod length. See model chart.

**Switch Type:** Snap action or mercury. See circuit charts A and B.

**Electrical Rating:** See charts A and B.

**Wiring Connection:** G, WT or E enclosure, terminal board. EV enclosure 18" (460 mm) leads.

**Process Connections:** T type 2-1/2" NPT. F type 2-1/2" flange standard.

**Enclosures:** G, painted steel and aluminum. WT, painted steel, aluminum and neoprene. E, aluminum. EV, aluminum and neoprene.

**Wetted Parts:** See model chart.

**Weight:** 500 T, 10 lb (4.5 kg); 500 F, 14 lb (6.4 kg).

### APPLICATIONS

Oil refineries, chemical plants, power generating stations, pumping stations, heat transfer systems, sanitary/waste water facilities, drip legs, hydraulic systems, boilers.

**MODEL CHART – SERIES 500**

<b>EXAMPLE</b>	500T	WT	7810	10	C1	55	12	500T-WT-7810-10-C1-55-12 Liquid level control. NEMA-4X weather proof enclosure. 2½" NPT cast steel threaded chamber for direct tank mounting. SPDT snap action switch fixed deadband, automatic reset. Operating pressure 200 PSI (14 BAR) to 425°F (218°C). Minimum specific gravity 0.55 with 6" (152 mm) float rod and 2½"×4" (64×102 mm) float.	
<b>CONSTRUCTION</b>	500T 500F							2½" NPT threaded process connection. Flanged direct mount process connection. 2½" 125 lb. Cast iron flange furnished for (C) cast iron chamber. 2½" NPT 150 lb. carbon steel flange furnished for (C1) cast steel chamber. 2½" NPT 150 lb. 316SS flange furnished for (C216) cast 316SS chamber. Other flange sizes available. Consult factory.	UL UL
<b>ENCLOSURE</b>	500 500 500	G WT E						General purpose, NEMA-1 enclosure. Watertight enclosure suitable for NEMA-1, 2, 3, 4, 4X. Explosion proof enclosure. NEMA-7, 9, Class I Groups B, C, D; Class II Groups E, F, G, Division I and II. Explosion proof, vapor proof enclosure. NEMA-7, 9, Class I Groups B, C, D; Class II Groups E, F, G, Division I and II.	UL UL UL UL
<b>CIRCUIT: SINGLE STAGE</b>			XXXX 78XXHM					Snap action or mercury switch (see Charts A and B). Hermetically sealed snap switch. See Chart B.	
<b>CHAMBER: SINGLE STAGE</b>					C	55		Cast iron chamber. Supplied with 6" (152 mm) 316SS float rod, 2½"×4" (64×102 mm) 316SS float and 316SS trim. Pressure rating 200 psig (14 bar) to 425°F (218°C) maximum. Minimum specific gravity 0.55.	UL
					C	80		Cast iron chamber. Supplied with 6" (152 mm) 316SS float rod, 2½" (64 mm) 316SS ball float and 316SS trim. Pressure rating 400 psig (28 bar) to 425°F (218°C) maximum. Minimum specific gravity 0.80.	UL
					C1	55		Cast steel chamber. Supplied with 6" (152 mm) 316SS float rod, 2½"×4" (64×102 mm) 316SS float and 316SS trim. Pressure rating 200 psig (14 bar) to 425°F (218°C) maximum. Minimum specific gravity 0.55.	UL
					C1	80		Cast steel chamber. Supplied with 6" (152 mm) 316SS float rod, 2½" (64 mm) 316SS ball float and 316SS trim. Pressure rating 400 psig (28 bar) to 425°F (218°C) maximum. Minimum specific gravity 0.80.	UL
					C216	55		Cast 316 stainless steel chamber. Supplied with 6" (152 mm) 316SS float rod, 2½"×4" (64×102 mm) 316SS float and 316SS trim. Pressure rating 200 psig (14 bar) to 425°F (218°C) maximum. Minimum specific gravity 0.55.	UL
					C216	80		Cast 316 stainless steel chamber. Supplied with 6" (152 mm) 316SS float rod, 2½" (64 mm) 316SS ball float and 316SS trim. Pressure rating 400 psig (28 bar) to 425°F (218°C) maximum. Minimum specific gravity 0.80.	UL
<b>CIRCUIT: TWO STAGE</b>			XXXX 78XXHM	XX				Snap action or mercury switch (see Charts A and B). Hermetically sealed snap switch. Consult factory.	
<b>CHAMBER: TWO STAGE</b>					C	70		Cast iron chamber. Supplied with 6" (152 mm) 316SS float rod, 2½"×4" (64×102 mm) 316SS float and 316SS trim. Pressure rating 200 psig (14 bar) to 425°F (218°C) maximum. Minimum specific gravity 0.70.	UL
					C1	70		Cast steel chamber. Supplied with 6" (152 mm) 316SS float rod, 2½"×4" (64×102 mm) 316SS float and 316SS trim. Pressure rating 200 psig (14 bar) to 425°F (218°C) maximum. Minimum specific gravity 0.70.	UL
					C216	70		Cast 316 stainless steel chamber. Supplied with 6" (152 mm) 316SS float rod, 2½"×4" (64×102 mm) 316SS float and 316SS trim. Pressure rating 200 psig (14 bar) to 425°F (218°C) maximum. Minimum specific gravity 0.70.	UL
<b>OPTIONS</b>							12	12" (305 mm), 18" (457 mm), or 24" (610 mm) float rods. Must be specified on order. Minimum specific gravity will increase (see chart). Breather and drain for E type enclosure. Recommended for high humidity or outdoor service.	

Level

**CHARTS A & B - ELECTRICAL CIRCUITS AND RATINGS**

SWITCH TYPE	SWITCH ACTION	ELECTRICAL RATINGS IN AMPS						ORDERING CODE			
		AC			DC			SINGLE STAGE	TWO STAGE		
		120V	240V	440V	30V	125V	250V		LOWER	UPPER	
<b>CHART A</b> Mercury Contacts	SP-ST Open on level FALL	10	5	3†		10	5	-4820	-4820	-20	UL
	SP-ST Open on level RISE	10	5	3†		10	5	-4821	-4821	-21	UL
	SP-DT One Switch	4	2	1†		4	2	-4810	-4810	-10	UL
	SP-DT Two switches E.I.*	10	5	3†		10	5	-4815	-4815	-15	UL
	DP-ST Two switches E.I.* Open on level FALL	10	5	3†		10	5	-4814	-4814	-14	UL
	DP-ST Two switches E.I.* Open on level RISE	10	5	3†		10	5	-4813	-4813	-13	UL
<b>CHART B</b> Snap Action Contacts	DP-DT Two SP-DT switches	4	2	1†		4	2	-4806	-4806	-06	UL
	SP-DT One switch	12	5	3†		0.5**	0.25**	-7810	-7810	-10	UL
	DP-DT Two SP-DT switches	12	5	3†		0.5**	0.25**	-7806	-7806	-06	UL
	SP-DT One hermetically sealed switch	5	5		5**			-7810HM	-7810HM	-10HM	
	DP-DT Two hermetically sealed SP-DT switches	5	5		5**			-7806HM	-7806HM	-06HM	
	DP-DT Two SP-DT switches	10	3			10‡	3‡	-9806	-9806	-06	
	SP-DT One switch	10	3			10‡		3‡	-9810	-9810	-10

\*Electrically Independent †Available on special order. Change 1st digit in Ordering Code from 4 to 5 or 7 to 8  
‡10 Amp inductive (Polarized) at 125 VDC i.e. -4820 becomes -5820, -7810 becomes -8810, etc.  
\*\* Resistive