



Series 201

Welded Construction



External Mount Pressures to 1000 psi (69 bar) at Temperatures to 750°F (400°C), Optional Explosion-Proof Enclosures, Hermetically Sealed Switches



Series 203 has one vertical and one horizontal flanged connection (1" RF forged steel - ANSI specifications). Flange centerline 14" (356 mm). Other centerlines available.



Series 201 is connected with one horizontal and one vertical 1" combination NPT and 1" pipe socket weld connection.

"A" is the level at which single (or lower stage) operates on level rise.
 "B" is the operating differential single (or lower stage) - drop in level to restore switch to original position.
 "C" is the level at which the upper stage operates on level rise.
 "D" is the operating differential of upper stage - drop in level to restore switch to original position.
 "E" - the increase in level above "A" to operate upper stage.

Repeatability ±1/4" (6.4 mm)

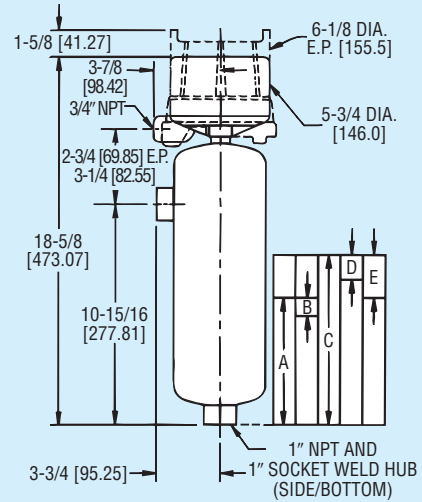

Series 204 features two vertical flanged connections (1" RF forged steel - ANSI specifications). Flange centerline 14 9/8" (371 mm). Other centerlines available.

Switch Level Change Single Stage Operation

Switch Level Change Two Stage Operation

	SP GR	A*	B	A**	B	C	D	E	ORDERING CODE
MIN SP GR 0.6 600 PSI (41 BAR) @ 100°F (38°C) 500 PSI (34 BAR) @ 750°F (400°C)	1.0	6 3/4" (171 mm)	3/4" (19 mm)	5 3/4" (146 mm)	3/4" (19 mm)	7 3/4" (197 mm)	1" (25.4 mm)	2" (51 mm)	C1-60
	0.6	7 1/2" (191 mm)	1" (25.4 mm)	6 1/2" (165 mm)	1" (25.4 mm)	9" (229 mm)	1 3/4" (44 mm)	2 1/2" (64 mm)	
MIN SP GR 0.75 1000 PSI (69 BAR) @ 100°F (38°C) 750 PSI (52 BAR) @ 750°F (400°C)	1.0	7 1/4" (184 mm)	3/4" (22 mm)	6 1/4" (159 mm)	3/4" (19 mm)	8 1/2" (216 mm)	1 1/4" (32 mm)	2 1/4" (57 mm)	C1-75
	0.75	8" (203 mm)	1" (25.4 mm)	7" (178 mm)	1" (25.4 mm)	9 1/2" (241 mm)	1 3/4" (44 mm)	2 1/2" (64 mm)	

**"A" is adjustable ±1".

***"A" is not adjustable.

Long life and reliable operation is inherent in the design of the 201 series. The heavy duty welded carbon steel chamber provides a control to operate up to 1000 psi (69 bar) and process temperature up to 750°F (400°C), 400°F (205°C) at the electrical head assembly. The use of an external magnet reduces the possibility of magnetic particle build up inside the armature tube and subsequent loss of operation as may occur with the internal magnet repulsion design. Choice of construction provides equipment suitable for specific gravity as low as (0.60). Electrical requirements are met by use of hermetically sealed snap action or mercury switches in a variety of actions including SPST, SPDT, DPDT and DPST arrangements. Optional circuits are available for low current/voltage DC; high current DC; or high temperature applications. Check the current chart for the switch best suited for your application. Standard process connections are combination 1" NPT and 1" socket weld hubs. Flanged connections are offered as an option.

APPLICATIONS

Refineries, chemical plants, power generating stations, water treatment plants, mixing systems, scrubbers, accumulators, condensate recovery, industrial tanks and vessels.

SPECIFICATIONS

C1-60: Minimum specific gravity 0.60. Process pressure 600 psig (41 bar) at 100°F (38°C). 500 psig (34 bar) at 750°F (400°C).*

C1-75: Minimum specific gravity 0.75. Process pressure 1000 psig (69 bar) at 100°F (38°C), 750 psig (52 bar) at 750°F (400°C).*

*Heat fins (HF) and/or high temperature switches should be considered for process temperatures above 500°F (260°C).

Switch Type: Snap action or mercury. See charts A and B.

Electrical Rating: See charts A and B.

Wiring Connections: G, WT or E enclosure, terminal block. EV enclosure 18" (460 mm) leads.

Process Connections: Combination 1" NPT/socket weld hubs or flanges. See chart C.

Enclosures: G, painted steel and aluminum. WT, painted steel, aluminum and neoprene. E, aluminum. EV, aluminum and neoprene.

Weight: 201, 27 lb (12.3 kg); 203, 37 lb (17 kg); 204, 44 lb (20 kg).

Suggested Specifications:

Liquid level control shall be 201 (203) (204) Series with combination 1" NPT/socket weld hubs (flanged) process connections. Chamber shall be welded suitable for operation at 1000 psig (69 bar) at 100°F (38°C), 750 psig (52 bar) at 750°F (400°C) at a minimum specific gravity of 0.75; or, 600 psig (41 bar) at 100°F (38°C), 500 psig (34 bar) at 750°F (400°C) at a minimum specific gravity of 0.60. Circuits shall be (hermetically sealed) snap action (mercury) switch (SPST) (SPDT), (DPDT). Enclosure shall be general purpose (weatherproof) (explosion-proof) (explosion-proof - vapor proof). Switch mechanism shall be gravity return and shall be actuated by a stainless steel float.

MODEL CHART – SERIES 201

EXAMPLE	201	WT	7810	10	HF	C1	60		201-WT-7810-C1-60. Liquid level control. Welded carbon steel chamber. Weather proof enclosure. SPDT snap switch, fixed deadband, automatic reset. Side/bottom process connections, combination 1" NPT/socket weld hubs. Minimum specific gravity 0.60. Operating pressure 600 psig (41 bar) at 100°F (38°C), 500 psi (34 bar) at 350°F (400°C).		
ENCLOSURE		G WT E EV							General purpose, NEMA-1. Weather proof, NEMA-3R, 4, 4X. Explosion proof, NEMA-7, 9. Class I Groups B, C, D. Class II Groups E, F, G. (CSA approved Groups C, D, E, F, G only). Explosion proof, vapor proof, NEMA-7, 9. Class I Groups B, C, D. Class II Groups E, F, G (CSA approved Groups C, D, E, F, G only).	UL UL UL	CSA CSA CSA
CIRCUITS (For Electrical Circuits see charts A & B below.)			48XX 48XX 78XX 78XX 78XXHM 98XX	XX XX					Single stage. Mercury switch. See Chart A. Two stage. Mercury switch. See Chart A. Single stage. Snap switch. See Chart B. Two stage. Snap switch. See Chart B. Hermetically sealed snap switch. See Chart B. Single stage. High capacity DC snap switch. Use heat fins (HF) if process temperature exceeds 350°F (177°C). Do not exceed 450°F (232°C). See Chart B. Two stage. High capacity DC snap switch. Use heat fins (HF) if process temperature exceeds 350°F (177°C). Do not exceed 450°F (232°C). See Chart B. Single stage. High temperature snap switch. Continuous rating 800°F (425°C). See Chart B. 201-C1-60 type rated at 500 psi (34 bar); 201-C1-75 type rated at 650 psi (45 bar). Two stage. High temperature snap switch. Continuous rating 800°F (425°C). See Chart B. 201-C1-60 type rated at 500 psi (34 bar); 201-C-75 type rated at 650 psi (45 bar).		
WELDED CHAMBER CONSTRUCTION COMBINATION 1" NPT/SOCKET WELD HUBS	201 201					C1 C1	60 75		Refer to Chart C for pressure/temperature ratings. Carbon steel body. Minimum specific gravity 0.60 side/bottom process connections. Combination 1" NPT/socket weld hub. Minimum specific gravity 0.75 side/bottom process connections. Combination 1" NPT/socket weld hub.	UL UL	CSA CSA
WELDED CHAMBER CONSTRUCTION WITH FLANGED PROCESS CONNECTIONS	203 203 203 203 203 203 204 204 204 204 204					C1 C1 C1 C1 C1 C1 C1 C1 C1 C1 C1	160 175 360 375 660 675 160 175 360 375 660 675		Refer to Chart C below for pressure/temperature ratings. 1" 150# flanges side/bottom process connection. 1" 150# flanges side/bottom process connection. 1" 300# flanges side/bottom process connection. 1" 300# flanges side/bottom process connection. 1" 600# flanges side/bottom process connection. 1" 600# flanges side/bottom process connection. 1" 150# flanges side/side process connection. 1" 150# flanges side/side process connection. 1" 300# flanges side/side process connection. 1" 300# flanges side/side process connection. 1" 600# flanges side/side process connection. 1" 600# flanges side/side process connection.	UL UL UL UL UL UL UL UL UL UL UL UL	CSA CSA CSA CSA CSA CSA CSA CSA CSA CSA CSA CSA
OPTIONS					HF			12	High temperature fins. Should be considered if ambient temperature exceeds 500°F (260°C) for extended periods. Breather and drain for E type explosion proof enclosure. Recommended for high humidity or outdoor service.		

Level

CHARTS A & B - ELECTRICAL CIRCUITS AND RATINGS

SWITCH TYPE	SWITCH ACTION	ELECTRICAL RATINGS IN AMPS					ORDERING CODE			UL	CSA
		AC			DC		SINGLE STAGE	TWO STAGE			
		120V	240V	440V	125V	250V		LOWER	UPPER		
CHART A Mercury Contacts	SP-ST Open on level FALL	10	5	3†	10	5	-4821	-4821	-21	UL	CSA
	SP-ST Open on level RISE	10	5	3†	10	5	-4820	-4820	-20	UL	CSA
	SP-DT One switch	4	2	1†	4	2	-4810	-4810	-10	UL	CSA
	SP-DT Two switches E.I.*	10	5	3†	10	5	-4815	-4815	-15	UL	CSA
	DP-ST Two switches E.I.* Open on level FALL	10	5	3†	10	5	-4813	-4813	-13	UL	CSA
	DP-ST Two switches E.I.* Open on level RISE	10	5	3†	10	5	-4814	-4814	-14	UL	CSA
CHART B Snap Action Contacts	DP-DT Two SP-DT switches	4	2	1†	4	2	-4806	-4806	-06	UL	CSA
	SP-DT One switch	12	5	3†	0.5**	0.25**	-7810	-7810	-10	UL	CSA
	DP-DT Two SP-DT switches	12	5	3†	0.5**	0.25**	-7806	-7806	-06	UL	CSA
	SP-DT One hermetically sealed switch**	5	5				-7810HM	-7810HM	-10HM		
	DP-DT Two hermetically sealed SP-DT switches**	5	5				-7806HM	-7806HM	-06HM		
	DP-DT Two SP-DT switches	10	3		10‡	3‡	-9806	-9806	-06		
	SP-DT One switch	10	3		10‡	3‡	-9810	-9810	-10		
	DP-DT Two SP-DT switches	2	2		0.4**	0.25**	-1006	-1006	-06		
SP-DT One switch	2	2		0.4**	0.25**	-1010	-1010	-10			

*Electrically Independent
‡10 Amp inductive (Polarized) at 125 VDC
**Resistive ** 30VDC = 5 Resistive
†Available on special order. Change 1st digit in Ordering Code from 4 to 5 or 7 to 8
i.e. -4820 becomes -5820, -7810 becomes -8810, etc.

CHART C

SERIES	MOUNTING STYLE	MINIMUM SPECIFIC GRAVITY	PRESSURE RATING AT		FLANGE CLASS (psi)	ORDER CODE
			38°C 100°F	400°C 750°F		
201	1" NPT	0.6	600 psi 41 bar	500 psi 34 bar	-	C1-60
201	1" NPT	0.75	1,000 psi 69 bar	750 psi 52 bar	-	C1-75
203 204	FLANGED	0.6	275 psi 19 bar	100 psi 7 bar	150	C1-160
203 204	FLANGED	0.75	275 psi 19 bar	100 psi 7 bar	150	C1-175
203 204	FLANGED	0.6	600 psi 41 bar	425 psi 29 bar	300	C1-360
203 204	FLANGED	0.75	720 psi 50 bar	425 psi 29 bar	300	C1-375
203 204	FLANGED	0.6	600 psi 41 bar	500 psi 34 bar	600	C1-660
203 204	FLANGED	0.75	1,000 psi 69 bar	750 psi 52 bar	600	C1-675