



Series 1261

Welded Chamber

External Mount, Pressure to 1750 psig (121 bar), and Temperature to 500°F (260°C), Hermetically Sealed Switches



Series 1263 has one vertical and one horizontal flanged connection (1" RF forged steel – ANSI specifications). Flange centerline 14" (356 mm). Other centerlines available.



Series 1261 is connected with one vertical and one horizontal 1" NPT and 1" socket weld combination connection.

"A" is the level at which single (or lower stage) operates on level rise.
 "B" is the operating differential single (or lower stage) – drop in level to restore switch to original position.
 "C" is the level at which the upper stage operates on level rise.
 "D" is the operating differential of upper stage – drop in level to restore switch to original position.
 "E" – the increase in level above "A" to operate upper stage.

Repeatability $\pm 1/4"$ (6.4 mm)

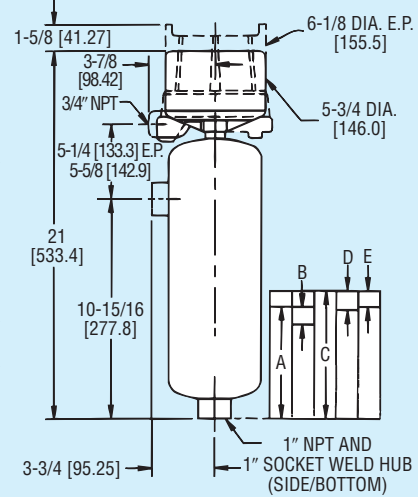

Series 1264 has two vertical flanges (1" RF forged steel – ANSI specifications). Flange centerline 14 5/8" (371 mm). Other centerlines available.

Switch Level Change Single Stage Operation (Non-Adjustable)

Switch Level Change Two Stage Operation (Non-Adjustable)

	SP GR	A	B	A	B	C	D	E	ORDERING CODE
MIN SP GR 0.6 1750 psi (121 bar) @ 100°F (38°C) 1650 psi (114 bar) @ 500°F (260°C)	1.0	5 1/2" (140 mm)	7/8" (22 mm)	5 1/2" (140 mm)	7/8" (22 mm)	6 1/4" (159 mm)	7/8" (22 mm)	3/4" (19 mm)	C1-60
	0.6	6" (152.4 mm)	1 1/8" (29 mm)	6" (152.4 mm)	1 1/8" (29 mm)	6 7/8" (175 mm)	1 1/8" (28.6 mm)	7/8" (22 mm)	

High pressure capability in a heavy duty welded carbon steel chamber provides a rugged heavy duty control to operate up to 1750 psi (121 bar) at 100°F (38°C), and 1650 psi (114 bar) at 500°F (260°C) with a minimum specific gravity of 0.60. Electrical enclosures are suited for general purpose NEMA-1, weatherproof NEMA-4X, explosion-proof or explosion-proof - vapor proof NEMA-7, 9 groups B, C, D, E, F, G, Division I and II requirements. Electrical requirements are met by use of hermetically sealed snap action or mercury switches in a variety of actions including SPST, SPDT, DPDT and DPST arrangements. Optional circuits are available for low current, low DC voltage, high DC current, or high temperature applications. Check the circuit chart for the switch best suited for your application.

APPLICATIONS

Oil refineries, chemical plants, power generating stations, pumping stations, heat transfer systems, sanitary/waste water facilities, drip legs, hydraulic systems, boilers.

SPECIFICATIONS

C1-60: Minimum specific gravity 0.60. Process pressure 1750 psig (121 bar) at 100°F (38°C), 1650 psig (114 bar) at 500°F (260°C).

Switch Type: Snap switch or mercury. See charts A and B.

Electrical Rating: See charts A and B.

Wiring Connections: G, WT or E enclosure, terminal block. EV enclosure, 18" (460 mm) leads.

Process Connections: Combination 1" NPT/socket weld hubs or flanges. See model chart.

Enclosures: G, painted steel and aluminum. WT, painted steel, aluminum and neoprene. E, aluminum. EV, aluminum, neoprene.

Wetted Parts: C1 construction is carbon steel, 303SS, 304SS and 430SS.

Weight: 1261, 79 lb (36 kg); 1263, 89 lb (40 kg); 1264, 92 lb (42 kg).

Suggested Specifications

Liquid level control shall be Mercoid 1261 (1263) (1264) Series with 1" combination NPT/socket weld hub (flanged) process connections. Chamber shall be welded and suitable for operation at 1650 psi (114 bar) and 500°F (260°C) with a minimum specific gravity of 0.60. Circuit shall be (hermetically sealed) snap action (mercury) switch (SPST) (SPDT) (DPDT). Enclosure shall be general purpose (weatherproof) (explosion-proof) (explosion-proof - vapor proof). Switch mechanism shall be gravity return and shall be activated by a stainless steel float.

MODEL CHART – SERIES 1261

EXAMPLE	1261	WT	7810	10	C1	60		1261-WT-7810-C1-60. Liquid level control. Welded carbon steel chamber. Weather proof enclosure. SPDT snap switch, fixed deadband, automatic reset. Operating pressure 1750 psig (121 bar) at 100°F (38°C), 1650 psig (114 bar) at 500°F (260°C). Side/bottom process connections, combination 1" NPT/socket weld hubs. Minimum specific gravity 0.60.	
ENCLOSURE		G WT E EV						General purpose, NEMA-1. Weather proof, NEMA-3R, 4, 4X. Explosion proof, NEMA-7, 9. Class I Groups B, C, D. Class II Groups E, F, G. Explosion proof, vapor proof, NEMA-7, 9. Class I Groups B, C, D. Class II Groups E, F, G.	UL UL UL UL
CIRCUITS (For Electrical Circuits see charts A & B below.)			48XX 48XX 78XX 78XX 78XXHM 98XX 98XX	XX XX XX				Single stage. Mercury switch. See Chart A. Two stage. Mercury switch. See Chart A. Single stage. Snap switch. See Chart B. Two stage. Snap switch. See Chart B. Hermetically sealed snap switch. See Chart B. Single stage. High capacity DC snap switch. Use heat fins (HF) if process temperature exceeds 350°F (177°C). Do not exceed 450°F (232°C). See Chart B. Two stage. High capacity DC snap switch. Use heat fins (HF) if process temperature exceeds 350°F (177°C). Do not exceed 450°F (232°C). See Chart B.	
WELDED CHAMBER CONSTRUCTION COMBINATION 1" NPT/SOCKET WELD HUBS	1261				C1 C1	60		Carbon steel body. Minimum specific gravity 0.60. Side/bottom process connections. Combination 1" NPT/socket weld hub. Pressure rating 1750 psig (121 bar) at 100°F (38°C), 1650 psig (52 bar) at 500°F (260°C).	UL UL
WELDED CHAMBER CONSTRUCTION WITH FLANGED PROCESS CONNECTIONS	1263 1264				C1 C1	660 660		1" 600# flanges side/bottom process connection. Pressure rating 1450 psi (99 bar) at 100°F (38°C), 1232 psi (84 bar) at 500°F (260°C). Minimum specific gravity 0.60. 1" 600# flanges side/side process connection. Pressure rating 1450 psi (99 bar) at 100°F (38°C), 1232 psi (84 bar) at 500°F (260°C). Minimum specific gravity 0.60.	UL UL
OPTIONS							12	Breather and drain for E type enclosure. Recommended for high humidity or outdoor service.	

Level

CHARTS A & B - ELECTRICAL CIRCUITS AND RATINGS

SWITCH TYPE	SWITCH ACTION	ELECTRICAL RATINGS IN AMPS						ORDERING CODE			
		AC			DC			SINGLE STAGE	TWO STAGE		
		120V	240V	440V	30V	125V	250V		LOWER	UPPER	
CHART A Mercury Contacts	SP-ST Open on level FALL	10	5	3†		10	5	-4820	-4820	-21	UL
	SP-ST Open on level RISE	10	5	3†		10	5	-4821	-4821	-20	UL
	SP-DT One Switch	4	2	1†		4	2	-4810	-4810	-10	UL
	SP-DT Two switches E.I.*	10	5	3†		10	5	-4815	-4815	-15	UL
	DP-ST Two switches E.I.* Open on level FALL	10	5	3†		10	5	-4814	-4814	-13	UL
	DP-ST Two switches E.I.* Open on level RISE	10	5	3†		10	5	-4813	-4813	-14	UL
	DP-DT Two SP-DT switches	4	2	1†		4	2	-4806	-4806	-06	UL
CHART B Snap Action Contacts	SP-DT One switch	12	5	3†		0.5**	0.25**	-7810	-7810	-10	UL
	DP-DT Two SP-DT switches	12	5	3†		0.5**	0.25**	-7806	-7806	-06	UL
	SP-DT One hermetically sealed switch	5	5		5**			-7810HM	-7810HM	-10HM	
	DP-DT Two hermetically sealed SP-DT switches	5	5		5**			-7806HM	-7806HM	-06HM	
	DP-DT Two SP-DT switches	10	3			10‡	3‡	-9806	-9806	-06	
	SP-DT One switch	10	3			10‡	3‡	-9810	-9810	-10	

*Electrically Independent
‡10 Amp inductive (Polarized) at 125 VDC
†Available on special order. Change 1st digit in Ordering Code from 4 to 5 or 7 to 8 i.e. -4820 becomes -5820, -7810 becomes -8810, etc.
**Resistive